

Electro - Pneumatic Strapping Head for 19 (32) mm steel strapping for small packs / coils

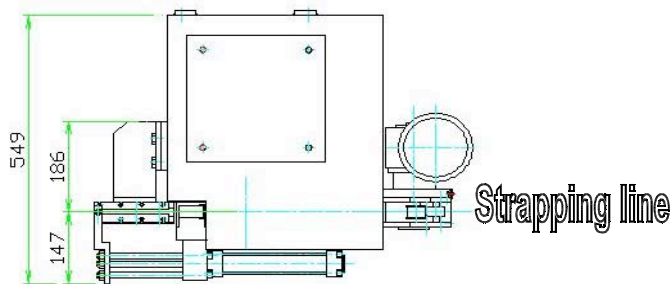
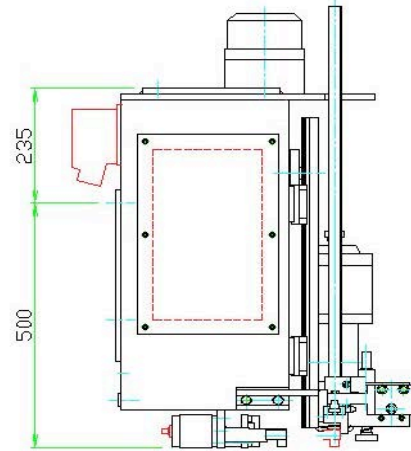
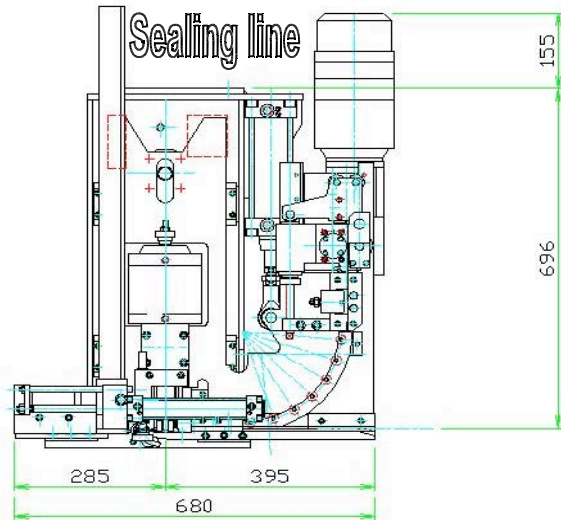

Item No.	Model	Strap width	Strap thickness	Electric supply
15.1510	MH150	19mm / 3/4"	0.64-0.9mm / .025"-.035"	400V/50Hz/3ph
15.1510-US	MH150	19mm / 3/4"	0.64-0.9mm / .025"-.035"	460V/60Hz/3ph
15.1530	MH150	32mm / 1 1/4"	0.64-1mm / .025"-.039"	400V/50Hz/3ph
15.1530-US	MH150	32mm / 1 1/4"	0.64-1mm / .025"-.039"	460V/60Hz/3ph

Technical Data

Weight	200 kg / 440 lbs	(400 kg / 880 lbs)
Dimensions	Height: 851mm / 33.5" Width: 680 mm / 26.7" Depth: 549 mm / 21.6"	(Height:851mm / 33.5") (Width:680 mm / 26.7") (Depth:549 mm / 21.6")
Strap feeding speed	0,6-1m/s /1.9-3.2 feet/sec (adjustable speed using frequency converter)	(0,7-1,2m/s /2.2-3.9 feet/sec)
Air consumption:	20 NLt/cycle	25 NLt/cycle
Electrical data Motor:	230/400 Volt; 1ph/3ph; 50Hz; 0,75 kW	(1,5 kW)
Strap:	19mm Steel strap – machine grade	(32mm)
Strap thickness:	0.63-0.9mm	(0.8-1mm)
Strap tension:	4000N (adjustable by potentiometer)	(10000N)
Push type seals:	45x22mm, two easy changeable magazines are supplied(45x35mm) 70 pieces/each	(70 pieces/each)

Smallest supporting surfaces for different packages:

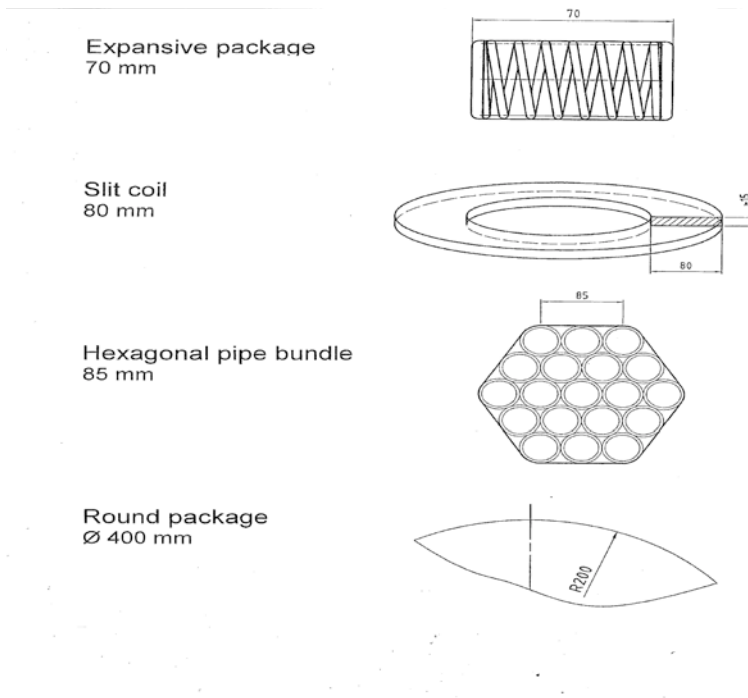

Advantages

- Heavy strong construction
- High reliability 98%
- The perfect double notch joint of the tool A482 (A483) guarantees 75% of the tensile strength of the steel strap (similar to 80% reached with 3 punches but a lot higher than 55% with 2 punches necessary for small packs/coils)
- All current steel straps can be used with elongation from 600-1100N/mm² / 87000-160000psi or galvanised
- Packs can be dirty or with grease (no problems like with welding joints)
- Using seals available in the market (competitors ask for their own seal)
- The strap is tensioned through a profiled tension wheel, driven by motor-gear frequency controlled, adjustment by pneumatic clutch with manometer
- No tension released (not necessary an opposite joint or the Microlock joint)
- Min. parcel width is 80mm (90mm for 32mm) with hard package, the min coil diam. is approx. 400mm.
- Small hexagonal tubes with 85mm side
- Strapping line asymmetric for slit coils: radial strap through the eye for coils with ext. diameter 700-800mm
- Circumferential strap for coils with ext. diameter aprox.400mm
- Strap feed and retract speed is frequency controlled and therefore adjustable
- Low wearing material; wearing parts in contact with the seal are made for A482 (A483) so available in stock
- Mechanical switch/sensor to detect the parcel
- Std Vertical installation including an head stroke to strap packs with similar packs (in a range of 50mm)
- Option lateral installation to strap packs with Hmin=350mm with strap line at 300mm
- Option horizontal installation to strap packs with Hmin=200mm with strap line at 150mm

Options

- Head movement by steering wheel to the best position / External floating device
- Vertical or horizontal sword, fix or moving machine, with top and or side press, telescopic arc
- Device to place bunks and or corners on top/bottom/sides positions

Markets

Iron industries:

Coils and slit coils
Flat metal sheets,
Pipes and steel bars,
Wires and tubes bundles

Aluminium industries

Coils,
Ingots,
Wires & tubes bundles